



The High Security Outdoor Pump offers the highest security features to ensure that the pump and its components are ready for action when its needed by the users. Designed for outdoor use in all climates, this pump is a perfect combination of ruggedness, durability and value and is a great solution for campus, city or other public heavy-use settings.

Product Specifications

- Outdoor-rated stainless steel construction, completely sealed
- Proprietary long-life piston seal and solid pump rod
- Steel braided air hose core prevents cutting
- Includes all-metal High Performance Pump Head with Presta and Schrader Valves
- Longer hose available with mounting clip
- Optional tools attached by stainless steel aircraft cable: (2) tire levers and (1) 15mm open end wrench
- 2 year warranty

Drawings are for informational purposes only. While correct at the time of design, Kinetic Parking Solutions, Inc. must confirm their accuracy prior to submission.

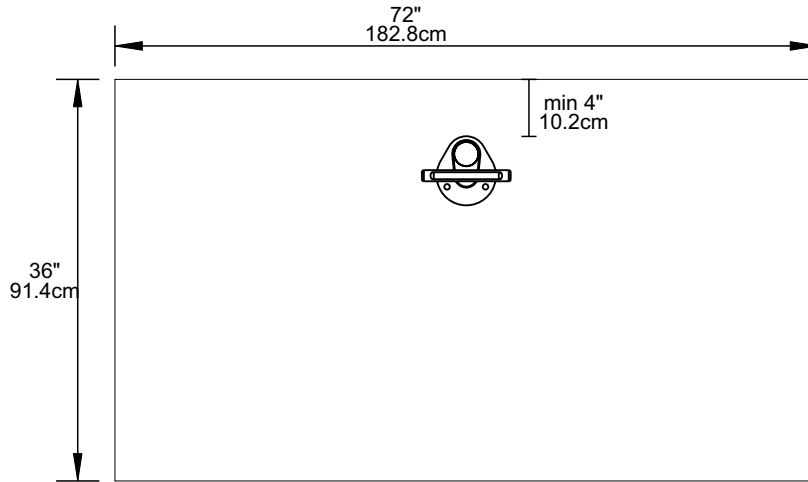

The minimum space requirements for High Security Bike Pumps are meant to allow a cyclist and their bike access to the pump.



MADE IN THE USA

Authorized Reseller



Dimensions						
Model #	Description	Type of Mount	Weight	Length	Width	Height
26240	Short Hose	Floor	20 lbs.	8"	8"	30"
26246	Long Hose	Floor	20 lbs.	8"	8"	30"
26242	Long Hose	Repair Stand	20 lbs.	8"	8"	30"

Drawings are for informational purposes only. While correct at the time of design, Kinetic Parking Solutions, Inc. must confirm their accuracy prior to submission.